

PV System with Neutral Point Clamped Inverter for Suppression of Leakage Current and Harmonics based Fuzzy Controller

P.T. Stephy¹, A. Anbarasan²

¹PG Student, Department of EEE, Erode Sengunthar Engineering College, Tamilnadu, India

²AP, Department of EEE, Erode Sengunthar Engineering College, Tamilnadu, India

Abstract—Multilevel inverter technology has emerged recently as a very important alternative in the area of high-power medium voltage energy control. This paper proposes a multilevel power conversion concept based on the combination of Neutral-Point-Clamped (NPC) and floating capacitor converters. In the proposed scheme, the voltage balancing across the floating capacitors is achieved by using a proper selection of redundant switching states, and the neutral-point voltage is controlled by the classical dc offset injection. Using NPC inverter results in the low frequency voltage harmonics in the NP, which is the point between the two dc-link capacitors. This explores the fundamental limitations of the NP voltage balancing problem for different loading conditions of three-level voltage source converters. The primary side, PV system harmonics are identified and eliminated by using fuzzy logic controller. It also represents that the most relevant control and modulation methods developed using the three-medium vector modulation technique. This process can involve the angular membership function for controlling the primary and secondary very effectively. The output voltage waveforms in neutral point clamped inverters can be generated at low switching frequency losses with high efficiency and low distortions. This paper presents a methodology of switching pattern to generate symmetrical gating signal to control NPCVSI using MATLAB/SIMULINK.

Keywords---Fuzzy Logic, Neutral Point Clamped Inverter, Multi-Level Inverter, Three-Medium Vector Modulation, Neutral Point Clamped Voltage Source Inverter.

I. INTRODUCTION

Multilevel converters have the later years been looked upon as a good choice for medium- and high-voltage applications. Before the introduction of multilevel converters the traditional solution has been to connect semiconductors in series to withstand the high voltages. This requires fast switching to avoid unequal voltage sharing between the devices, which could lead to a

breakdown. Multilevel converters have the advantage of clamping the voltages, which prevents the need of fast switching. MLC also have a smoother output voltage than traditional two-level converters. As wind turbines are increasing in power ratings, multilevel converters can be well suited in such applications.

The most popular multilevel converter and the one that will be studied in this report is the neutral point clamped three-level converter. One of the challenges with the NPC three-level converter is the increased complexity in the control of it. A lot of research have been done on this converter topology and a numerous of control methods have been presented in the literature. Still there is a focus of how to solve the voltage fluctuation between the two capacitors and most of the research today is to improve the DC-bus balance.

There will also be a comparison of asymmetrical and symmetrical modulation. Since their output voltage is a modulated staircase, they outperform two-level PWM inverters in terms of total harmonic distortion (THD), without the use of bulky expensive and dissipative passive filters. Therefore, recently, they have been proposed in the field of renewable energies, including photovoltaic (PV) generators. DC-bus balancing was studied in detail in the previous project and in this master thesis a PI controller is included.

The reason for studying the currents is to see if exist any difference which could increase the stresses on the capacitors and conductors. The voltage between two phases, the line-to-line voltage can achieve five different voltage levels. By combining the different states a bridge leg can have it is possible to get a close to sinusoidal averaged bridge leg output.

II. NPC INVERTER FOR PV APPLICATIONS

Each dc generator consists of PV cell arrays connected in series and/or in parallel, thus obtaining the desired output voltage and current. Three-phase systems can be realized by delta or wye connection of three single-phase systems. However, the number of levels increases the complexity

and the cost of the system while reducing its switching frequency in comparison with two-level converters. The converter studied in this project is a Neutral-Point-Clamped three-level converter with three bridge legs. "Three-level" means that each bridge leg, A, B and C can have three different voltage states. The converter topology can be seen in Figure 1. Switch 1 and 3 on each leg are complementary, which means that when switch 1 is on, switch 3 is off and vice versa. Switch 2 and 4 is the other complementary switching pair.

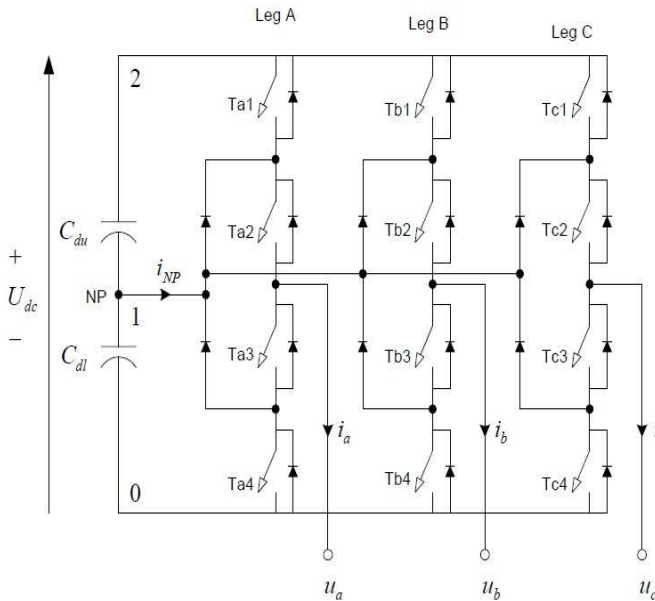

Fig.1 NPC converter topology

If each of the capacitors has a constant voltage of 0.5 U_{dc}, then having the two upper switches on will give an output voltage of U_{dc} compared to level 0, switch 2 and 3 on will give 0.5 U_{dc} and by having the two lower switches on, an output voltage of 0 will occur. In addition to these three states there is a forbidden state where the first switch is on while the second is off.

Table.1: Bridge leg voltages at different combinations of switch states

Leg State	U _{a0}	T _{a1}	T _{a2}	T _{a3}	T _{a4}
2	U _{dc}	ON	ON	OFF	OFF
1	0.5 U _{dc}	OFF	ON	ON	OFF
0	0	OFF	OFF	ON	ON

The combination of states for the bridge legs gives in the space vector table 1. Space vector 210 means that bridge leg A is in state 2, leg B in state 1 and leg C in state 0. Some of the switching states give the same space vector as is seen for the inner vectors. All the modulation strategies discussed in the subsequent chapters use combinations of these switching states. The difference between the modulation strategies is the combinations of states and their respective extent.

In order to get the model as close as possible to real implementation parameters concerning minimum on/off-time and dead time are included. Dead time is included to avoid the possibility of short circuiting the DC-side.

In other words will not the complementary switch be turned on before the other switch has been off for at least the dead time. Minimum on- and off-time is the minimum time a switch has to be on or off in order to switch. For instance if a switch is supposed to be turned on, but will not be on as long as the minimum time, then it should just be kept off.

The gain of the output voltage to have the switch on for such a short time compared to the switching losses is very low or might be negative. With non-ideal switch there is also a limit of how fast a switch can be turned on and off, hence it might need the minimum on/off-time. The control of the switches is done in periods named triangular periods. In one period there is a maximum of one turn on and one turn off of a switch. The time a switch is on in a period relative to the length of the period is the duty cycle of the switch.

$$d_{ij} = \frac{t_{on}}{T_{tri}}, i = \{a, b, c\}, j = \{1, 2\}$$

These duty cycles range between 0 and 1. The duty cycles of switch 3 and 4 for the bridge legs not defined since they are complementary to switch 1 and 2. Meaning the duty cycle of switch 3 is one minus the duty cycle of switch 2. Modulation is done by calculations of these duty cycles. The voltage between two phases figure 2, the line-to-line voltage figure 3 can achieve five different voltage levels. This can showed below:

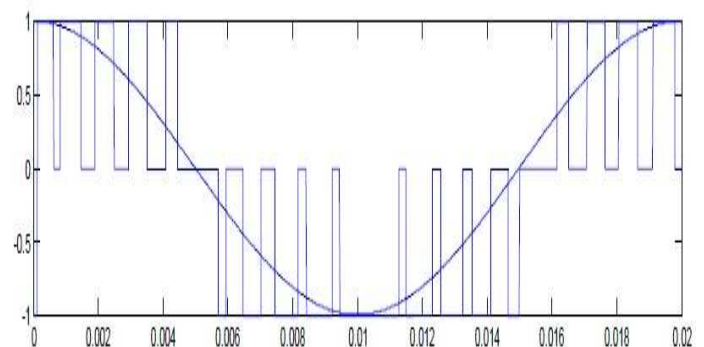

Fig .2 Converter leg voltages

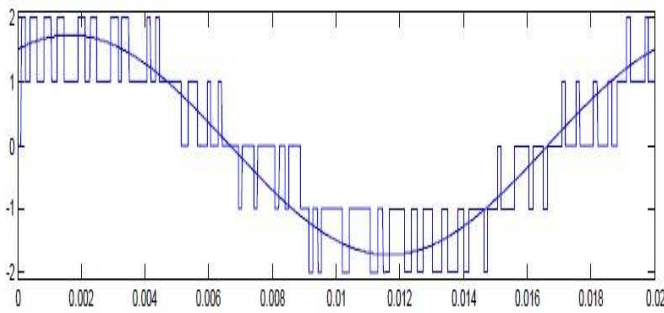

Fig .3 Line to Line voltages

Converters with a higher number of levels will give a smoother output of the converter. These duty cycles range between 0 and 1. The duty cycles of switch 3 and 4 for the bridge leg is not defined since they are complementary to switch 1 and 2. Meaning the duty cycle of switch 3 is one minus the duty cycle of switch 1. Modulation is done by calculations of these duty cycles. If it is assumed that each of the capacitors has the same voltage $U_{dc}/2$; the bridge leg voltage can be expressed as:

$$U_{a0} = \frac{U_{dc}}{2} d_{a2} + \frac{U_{dc}}{2} d_{a1}, d_{a2} > d_{a1}$$

The modulating strategies base their calculations on DC-bus balance. This is done by control of the neutral point current. The control of the neutral point current is related to the choice and extent of the switching states. This is done by adding additional conditions to the calculation of switch duty cycles for the different modulation strategies.

2.1 MODULATION STRATEGIES

The different conversion process and switching strategies for a three-level converter is controlled by three-medium vector modulation. Three-medium vector PWM is a popular modulation method for converters, due to its low harmonics. The theory of space vector is that phase A, B and C has a permanent position to each other in the vector space, phase shifted with 120 degrees.

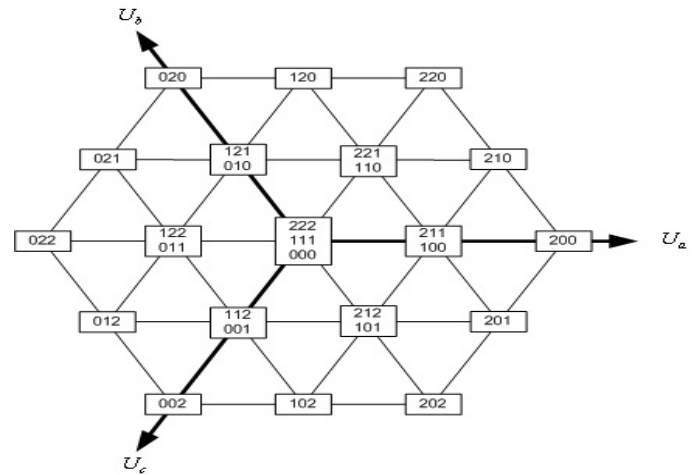

Fig.5 Space vector diagram for a three-level converter

By using these vectors in a correct manner the average of them will be the reference vector, by saying that the switching frequency is much higher than the fundamental frequency. A three-level converter has 27 vectors that can be used to create the desired voltage, with 19 different states, which can be seen in Figure 5:

There are a lot of vectors to choose among for a three-level converter, and the normal way of solving this is to choose the three vector states closest to the reference vector when using Space Vector modulation. The reason for this is that the harmonic distortion will be the lowest with this choice.

Table.2: Space vectors for three-levels

Zero vectors	Small vectors	Medium vectors
(000)	(100),(211),(110),(221),	(210),(120)
(111)	(121),(010),(011),(122),	(021),(012)
(222)	(001),(112),(101),(212)	(102),(201)

The table.2 shows for, switching pattern should be designed in a way which minimizes the number of switching transitions. In this report the aim has not been to minimize the number of switching transitions, but to be able to balance the DC-bus. It is starting off with vector 000 and moving on to 100 and so on, such that there is one switching transition between every new vector, for instance not to use the order 000, 200, 100 and 210.

With this switching pattern all the vectors are being used, and the possibility of using the vector redundancy is maximized. The major drawback of using all of the vectors is that there will be an increase in the switching losses. Atleast should either 000 or 222 be removed since they give the same state. Hence other methods should be considered such that the switching losses may be reduced in switching pattern figure 6.

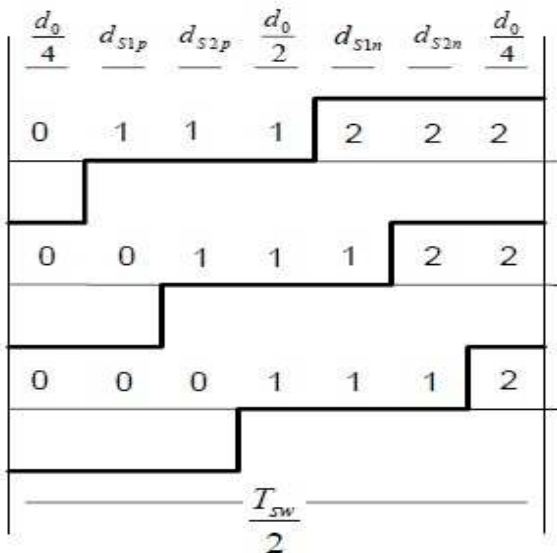

Fig.6 Switching pattern for three-medium vector modulation

The positive signal will be compared to the upper triangular signal, while the negative signal will be compared with the lower triangular signal. By adding some offset signals to the new signals the DC-bus can be controlled. The proposed block diagram is shown for figure 7.

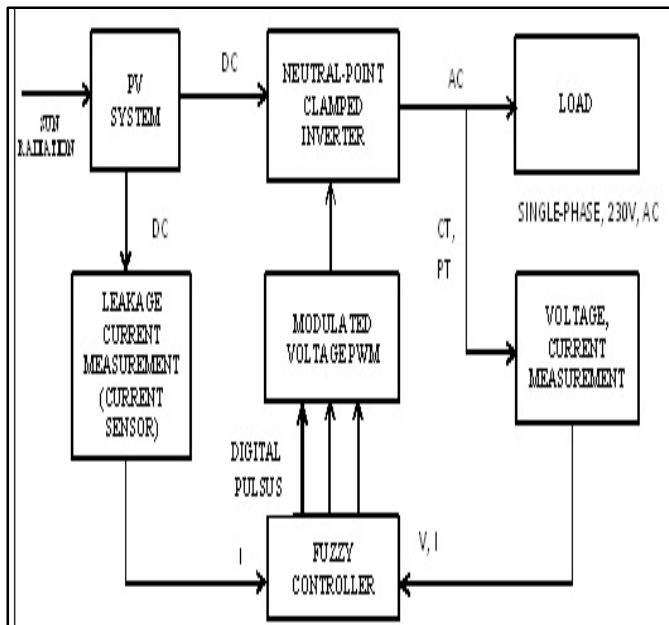

Fig.7 Block diagram for developed system

III. INTEGRATED FLC/MODULATOR

3.1 Overview

Fuzzy logic (FL) was successfully adopted, often in combination with genetic algorithms and neural networks, in the control of dc and ac drives and in the tuning of state observers, the latter introduced in the control loop for enhancing its behaviour. Its use in power converter control

and modulation was mainly in the field of dc/dc converters.

This situation probably depends on the high computational speed required by conditional and branch statements, typical of FLC. Fuzzy logic in the field of multilevel converters, proposing a controller combining optimal PWM switching-angle generator and fuzzy controller. An FLC, instead, does not require neither detailed knowledge of the process under control nor its precise description in terms of mathematical model and often, if well designed, outperforms more complex controllers because it adapts its outputs to the actual state of the system even without the use of observers.

3.2 Controller/Modulator Design and Analysis

It consists of four PV arrays (represented by variable voltage sources v_{dc}), the nine-level inverter, a low-pass filter, the load, and the grid. The input variables to the FLC are as follows:

- 1) V_n , i.e., the inverter output voltage V_{out} divided by 100, measured after a low-pass filter (for both PV and PQ controls);
- 2) The difference between the actual and reference signals,

- a) $\Delta I_{diff} = I_{outinv} - I_{ref}$ (PQ control);
- b) $\Delta V_{diff} = V_{outinv} - V_{ref}$ (PV control).

Both I_{outinv} and V_{outinv} are measured after a low-pass filter at the load terminals. This choice improves the quality of the control without introducing delays; filter bandwidth is chosen around 1 kHz with resistive load. The output of the controller is applied to the inverter gate drivers. The normalized input V_n is used in order to identify the actual inverter operating state. Both the latter and the FLC output may assume nine different states, i.e., integer values bounded within the limited range. The proposed circuit diagram figure.8 is shown for the overall control of Fuzzy Logic Controller system.

The first step during the FLC design was the creation of a knowledge base, i.e., fuzzy rules, expressed in terms of statements, conditions, and actions. Starting from the condition "TRUE" (i.e., the situation is verified), a set of rules was defined for the errors.

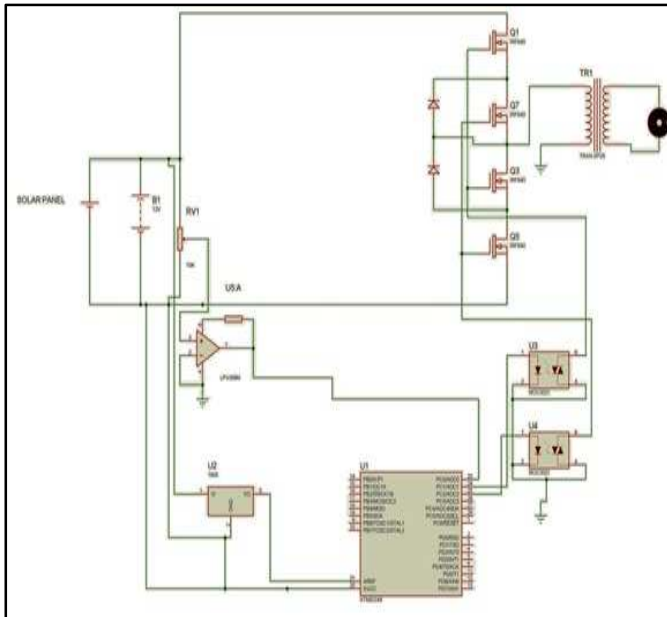

Fig.8: Circuit diagram for developed system

Then, conditions were defined accordingly, obtaining variable reactions. The number and type of membership functions (MFs) represent a key point for the controller, being a trade-off among achievable performance, memory space occupation, and execution speed.

Their shape depends on the input data distribution and can influence both the tracking accuracy and the execution time. Although any convex shape can be adopted, the most common are the triangular, trapezoidal, or Gaussian ones. In this paper, the knowledge base was obtained through experimentation with the system and its dynamics. Triangular shapes were chosen for input and output MFs because of their satisfactory performance and simpler implementation using MATLAB.

IV. SIMULATION RESULTS

The proposed system was simulated using Simulink of matlab Toolbox. Different tests were carried out, considering the inverter operations.

4.1 HARMONIC ELIMINATION WITH FFT ANALYSIS:

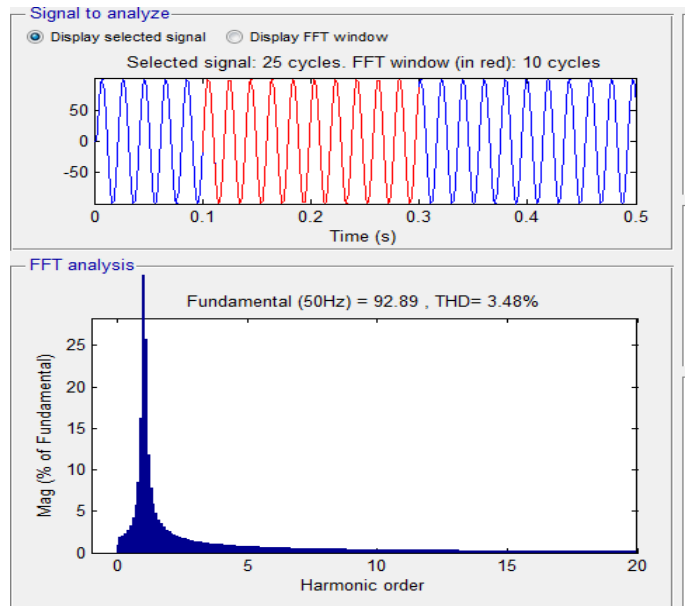

Fig. 9 Harmonic elimination of FFT analysis

In this part there have been done some simulations in order to compare the different balancing strategies. In all the simulations the amplitude has been 1000 amps for all of the phase currents. In the switching frequency was set to be 1000 Hz, while in this report it will be 1050 Hz. The order of harmonics is eliminated by fuzzy controller. The name of fast Fourier transform analysis can useful to show the variation of eliminating harmonic order in inverter circuit.

4.2 LEAKAGE CURRENT ELIMINATION:

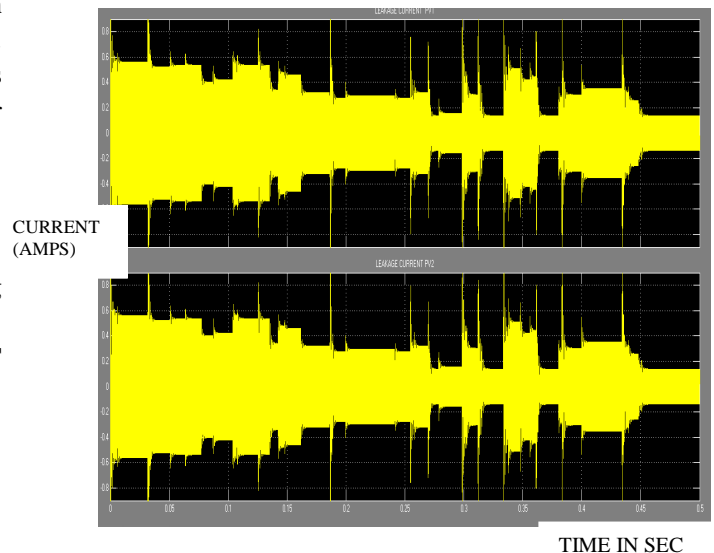

Fig.10Elimination of leakage current in PV panel

The leakage current elimination is shows for the each PV panels. The current is reduced by 0.9amps to 0.2amps in the above figure.9. When the PV has generates the power the leakage current is measured by using current sensors. This elimination is controlled by fuzzy logic controller.

4.3 LOAD VOLTAGE AND THREE-PHASE CURRENT:

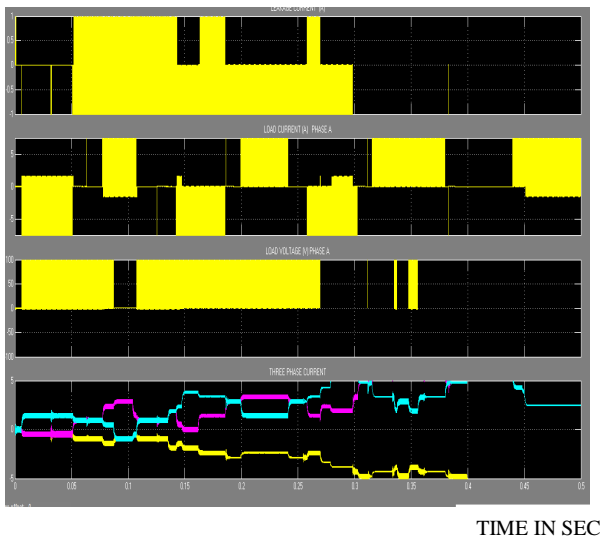

Fig. 11 output current and load voltage

The PV system consisting of the dc injection in the primary side voltage. That process can connect with load voltage and the inverter side connects with the three-phase output. With the help of fuzzy controller the output efficiency is high.

V. CONCLUSION

A Three-level Neutral Point Clamped inverter with fuzzy controller is developed in such a manner that both elimination of leakage current and harmonics. By balancing the DC-link capacitor voltage in inverter side, across the entire modulation range using only the switching state redundancies. This will make the power circuit simpler to fabricate, when compared to any of the other existing topologies. The simulation results using MATLAB are confirmed the capability of the developed scheme to provide the elimination for leakage current as well as the harmonics to the entire range of operation with high efficiency.

REFERENCES

- [1] F. Z. Peng and J. S. Lai, "Multilevel cascade voltage source inverter with separate dc sources for reducing the leakage current," U.S. Patent 5 642 275, Jun. 24, 2013.
- [2] "Space vector modulation technique for three level diode clamped inverter" by mallikarjuna g. d, r. l. naik and suresh h. jangamshetti, feb 2013.
- [3] Active-Neutral-Point-Clamped (ANPC) Multilevel Converter Technology Peter Barbosa¹, Peter Steimer², Jürgen Steinke² in Jan 2013.
- [4] Application of a Three-level NPC Inverter as a Three-Phase Four-Wire Power Quality Compensator by Generalized 3DSVM Ning-Yi Dai, *Student Member*,

IEEE, Man-Chung Wong, *Member, IEEE*, and Ying-Duo Han, *Senior Member, IEEE*

- [5] S. Ogasawara, and H. Akagi, "Analysis of variation of neutral point potential in neutral point clamped voltage source PWM inverters", Proc. IEEE Industry Appl. Society Annual Meeting IAS, Toronto, Ontario, Canada, 2013, pp. 965-970.
- [6] A Multilevel Inverter for Photovoltaic Systems With Fuzzy Logic Control Carlo Cecati, *Fellow, IEEE*, Fabrizio Ciancetta, *Member, IEEE*, and Pierluigi Siano
- [7] Zaragoza, Pou, Ceballos, Robles, Jaen, Corbalàn: Voltage-Balance Compensator for a Carrier-Based Modulation in the Neutral-Point-Clamped Converter, *IEEE Trans. Ind. Elect.*, vol 56, no. 2, pages 305-314, Feb 2012.